



# STOKER-FIRED WARM AIR FURNACE Model AF

For economical home heating, more home-owners are rediscovering the benefits of anthracite coal. The move toward this abundant source of American energy has prompted the rediscovery of perhaps the most reliable anthracite-burning heating unit



American home-owners have ever known: the EFM Stoker-fired Warm Air Furnace.

The rugged furnace is still manufactured with the same quality workmanship and matched components that helped earn its reputation. It is completely automatic, simple in design and all moving parts are accurately machined for quiet operation.

Coal is automatically moved from bin to burner. Ash is neatly deposited in a container in the unit's dust-tight base.

The burner operates with a clean, smokeless flame which is controlled by the thermostat...the intensity of the flame is adjusted with fingertip control.

Operation is fully automatic and the EFM Stoker-fired Warm Air Furnace can be relied upon for safe, unattended operation.

Ask your EFM dealer for complete details on how a Stoker-Fired Warm Air Furnace can save you heating dollars in your home.



**e·f·m Sales Company**  
Emmaus, PA 18049  
610-965-9041

## FEATURES

- Furnace—extra heavy, welded construction, no collection of fly ash on vertical surfaces
- Beautiful azure blue durable powder coat jacket thoroughly insulated against heat loss
- Right or left hand coal conveyor
- Conveyor worms of stainless steel—resists corrosion
- Heat resistant burner—Burns inexpensive rice anthracite

- Air and Coal carburetion can be readily adjusted
- Ratchet drive— No belts, gears or pulleys to change
- Machined alignments—Quiet operation
- Fines clean-out provides unobstructed supply of combustion
- Cost of maintenance about half that of other makes
- Installation by factory trained dealers

## DIMENSIONS AND SPECIFICATIONS

### STANDARD EQUIPMENT

Complete furnace unit with fan, filters, stoker, ash receptacle, bin feed worm, pipe (standard 2" pipe), and controls.

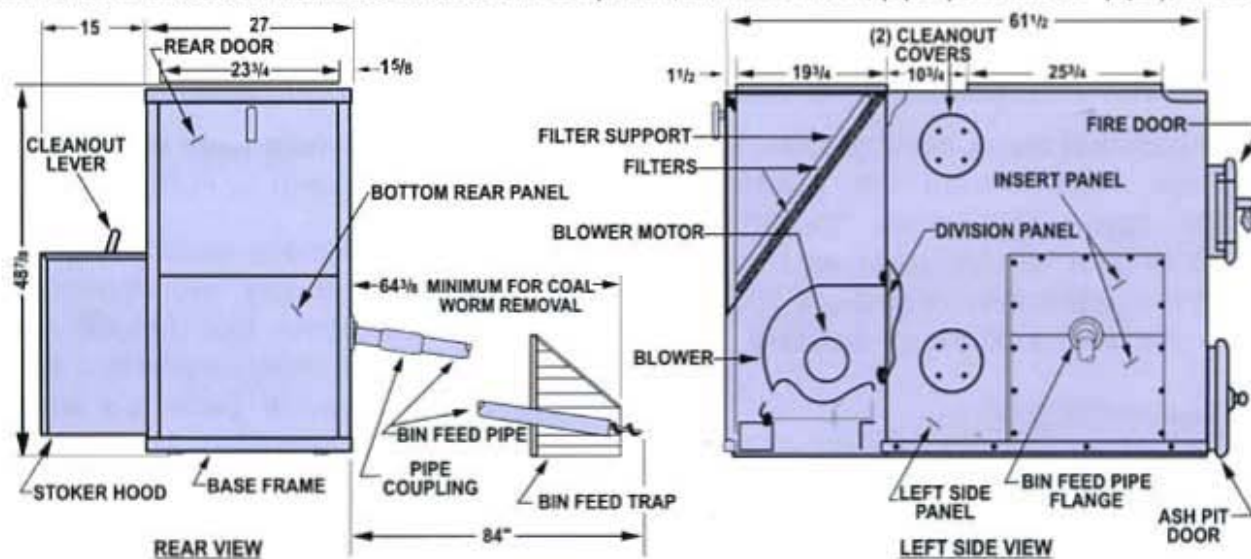

**NOTE:** Bare heat exchanger dimensions: Width - 30 1/4", Length - 41", Height - 46"

MODEL	AF
Bonnet Output Btu/Hr	150,000 maximum
Recommended Firing Rate, Lb/Hr	10 to 17.5
Blower Capacity, 75°F, Rise, CFM	1800
Warm Air Outlet	24" x 26"
Return Air Inlet	24" x 20"
Blower Wheel - Direct Drive	10" x 11"
Blower Motor, HP	1
Stoker Motor, HP	1/8
Smoke Outlet	8"
Filter Size (2)	16" x 25" x 1"
Recommended Chimney Size	8" x 8" x 15'
Complete shipping weight, lbs.	800

"Pounds of coal per Hour" should never be used as a basis of comparison of stoker capacities. Various systems of the handling of air result in varying combustion results. Always use certified B.T.U. output ratings.

**e·f·m Sales Company • Emmaus, PA 18049 • 610-965-9041**



**AUTHORIZED DEALER**

**MEYERS SUPPLY**  
520 HORNER ST.  
JOHNSTOWN, PA 15902  
(814) 536-2387